

WPC1-XXXX-T

Rated for use on 110/120VAC 60Hz and 220/240VAC 60Hz applications

Installation Instructions: Read these instructions in their entirety before performing any installation work.

FOR USE WITH POOL AND SPA PRODUCTS

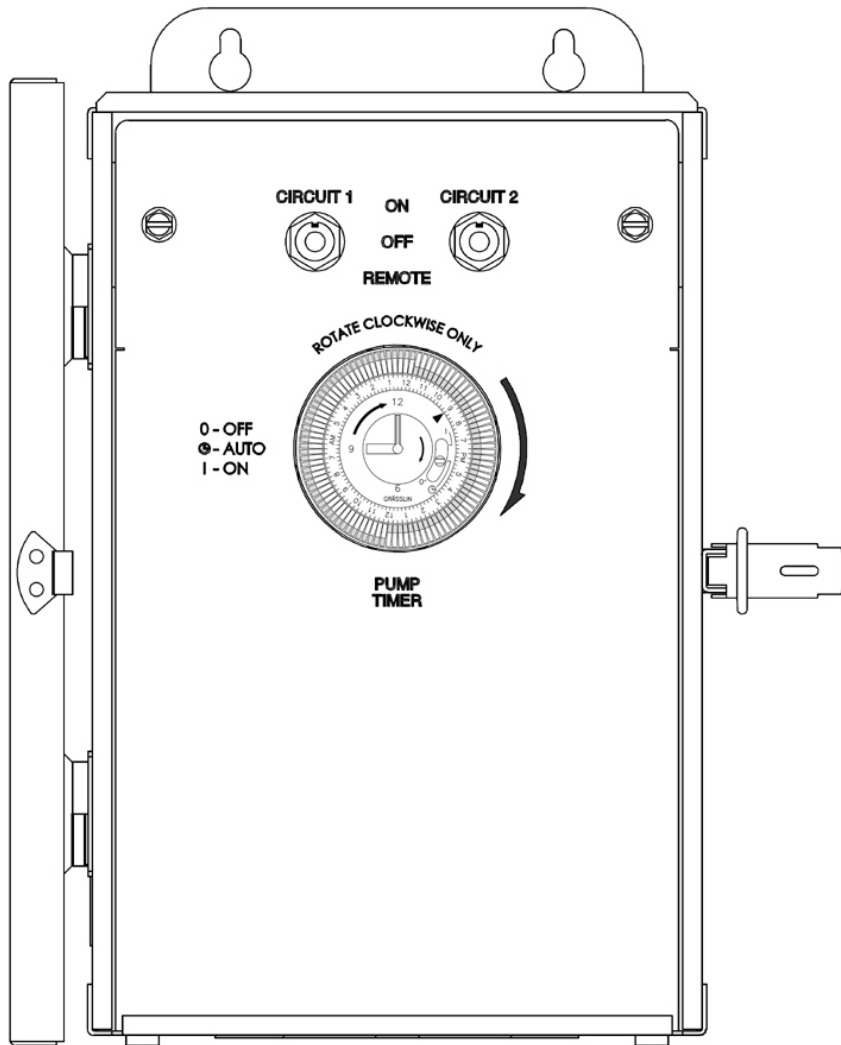

ETL LISTED
Conforms to UL STD 379;
Certified to CSA STD C22.2 #218.1



Intertek
4008814

The WPC1-XXXX-T consists of the following parts:

Item No.	Qty.	Component part No.	Description
1	1	94-15086-00	WPC1-XXXX-T Enclosure
2	1	94-15087-00	WPC-1 Enclosure Door
3	1	37-15000-00	Relay
4	1	41-15004-08	8 Position Terminal Block
5	1	42-15032-00	Timer
6	1	02-15268-00	Face Plate
7	2	02-15274-00	WPC-1 Mounting Bracket
8	1	41-15003-00	Grounding Bar
9	1	94-15255-00	WPC Receiver
10	6	10-15086-04	Face Plate and Mounting Bracket Screws
11	2	10-15089-06	Terminal Block Mounting Screw
12	1	10-15060-01	Relay Mounting Screw
13	8	10-15089-03	Timer and Receiver Mounting Screws
14	2	A11526	3-Position Toggle Switch
15	1	94-15257-00	WPC Repeater
16	1	44-15037-00	Transformer, 12V
17	1	20-15013-00	Strain Relief
18	1	17-15005-00	Latch
19	2	10-15089-01	Latch Mounting Screws
20	3	A10670	Transformer & Relay Mounting Screws
21	3	11-15022-00	Hex Nut, Kep

Accessory Items:

WE-65	65 ft Repeater Cord Extension Kit
DL-HUB	Direct Light Hub Connection Kit
FP 1/2	Temperature Freeze Device

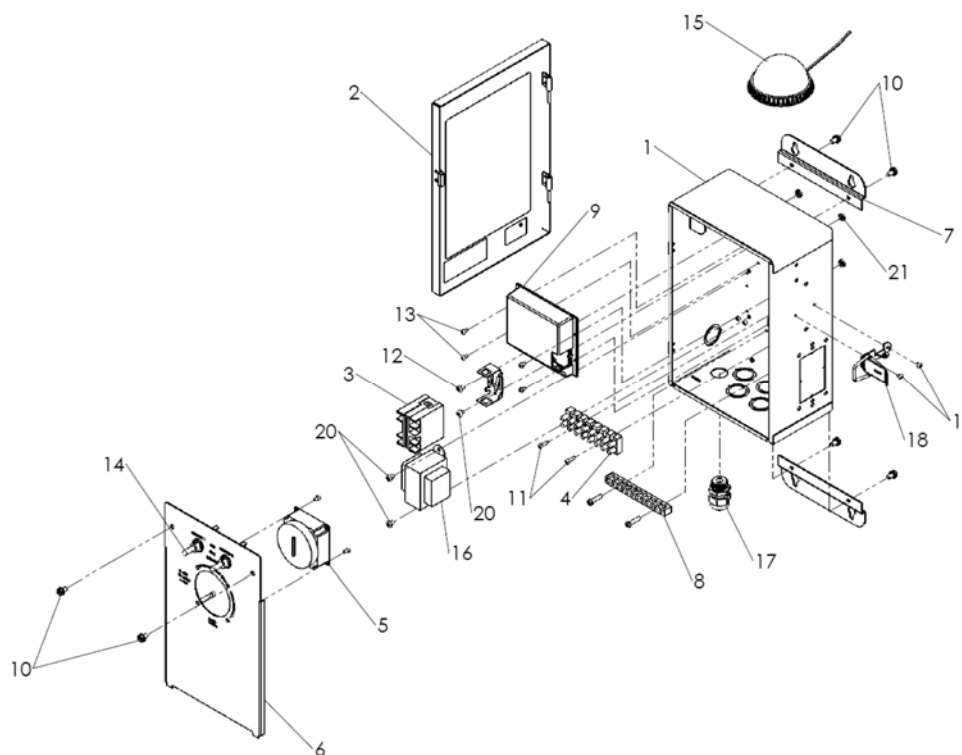



SAVE THESE INSTRUCTIONS!

IMPORTANT SAFETY INFORMATION

Basic safety precautions should be observed when operating the WPC-1 product and other associated equipment.

1. A qualified electrician must install the WPC-1 in accordance to the National and Local Electrical Codes.
2. The WPC-1 must not be less than 5 feet (3 meters in Canada) from inside edge of pool. **ONLY USE COPPER CONDUCTORS.**
3. Do not exceed the maximum ratings of individual components, wiring devices, and current carrying capacity of conductors.
4. For the bonding, grounding, installing, and wiring of underwater lights to the WPC-1, refer to Article 680 of the National Electrical Code or Article 68 of the Canadian Electrical Code.
5. This device should never operate equipment that could cause property damage, bodily injury, or death should it be activated unexpectedly.
6. Never allow children to operate the WPC-1 unsupervised.

FCC WARNING

1. This device complies with Part 15 of the FCC Rules. Operation is subject to the following two conditions: (1) this device may not cause harmful interference, and (2) this device must accept any interference received, including interference that may cause undesired operation.
2. Changes or modifications not expressly approved by S.R Smith. could void the user's authority to operate the equipment.

ELECTRICAL RATINGS

Do not exceed the maximum electrical ratings of the WPC-1. A circuit breaker rated at 20Amps at 120VAC must be installed in the breaker panel to connect to the WPC-1 power input. Circuit 1 is rated for use of up to 2.5 amps @12VAC, and Circuit 2 is rated for use of up to 8 amps @ 120VAC. The Pump Relay is rated at a maximum of 3HP @ 240VAC.

WARNING

- TURN OFF INCOMING POWER BEFORE SERVICING EQUIPMENT.
- ALL INSTALLATION AND MAINTENANCE WORK MUST BE PERFORMED BY QUALIFIED ELECTRICAL PERSONEL ONLY.
- VERIFY ALL ELECTRICAL RATINGS BEFORE INSTALLATION IS COMPLETE.

LOCATION

Install the WPC-1 enclosure using the mounting plates included with each enclosure. The WPC-1 is housed in a Type 3R rainproof enclosure and can be mounted anywhere between the pool equipment and the breaker panel.

WIRING INSTRUCTIONS

FOLLOW PROPER WIRING PRACTICES IN ACCORDANCE WITH ALL LOCAL REGULATORY REQUIREMENTS. **IF USING WITH LOW VOLTAGE POOL LIGHTING, SEE PG. 6 FOR ADDITIONAL REQUIRMENTS AND MATERIALS.**

Power Connections without lighting:

To wire the WPC-1 use insulated COPPER wire only, 12 gauge minimum. Run a 1/2" to 3/4" conduit from the main breaker panel to one of the bottom right knockouts of the WPC-1. Pull appropriate wires from the main breaker panel to the WPC-1 unit. To make power connections remove 3/8 inches of insulation from wire ends. Insert the bare end of wires under the pressure plate of terminals (Power Input, **HOT**). Use 1/8-in. flat head screwdriver to tighten terminal screws firmly (10.0 in-lbs. minimum). Connect the house common to the Power Inputs **NEUTRAL** terminal. Connect another **HOT** wire to the Timeclocks **T/C POWER** terminal. Connect a house common to the Timeclocks **T/C NEUTRAL**. Install a 20 Amp circuit breaker in the main breaker panel and connect the **HOT** wires from the WPC-1.

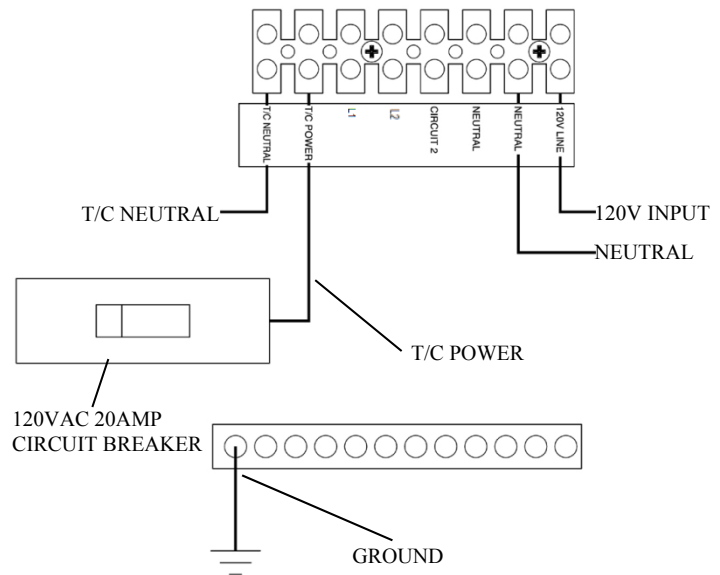

Power Connection with GFCI for lighting use:

To wire the WPC-1 with the use of a GFCI, punch out the GFCI knockout on the side of the WPC-1 enclosure. Install an outdoor rated GFCI. Using **COPPER** wire only, 12 gauge minimum, connect the GFCI from the **LOAD** side to the **HOT** terminal on the **POWER INPUT** of the WPC-1. Connect the **NEUTRAL** from the **LOAD** side of the GFCI to the **NEUTRAL** terminal from the WPC-1. Connect the **GROUND** of the GFCI to the **EQUIP. GND.** bar. Wire the **HOT** from the GFCI's **LINE** side to the 20Amp circuit breaker in the main breaker panel as discussed earlier. Connect the **NEUTRAL** from the GFCI's **LINE** side to the house common. From the GFCI's **LINE** side, connect a wire from the **HOT** to the Timeclocks **T/C POWER** terminal. From the **NEUTRAL** of the **LINE** side on the GFCI, connect to the **T/C NEUTRAL** on the terminal block. **NOTE:** Do not connect the Timeclock Inputs to the **LOAD** side of the GFCI.

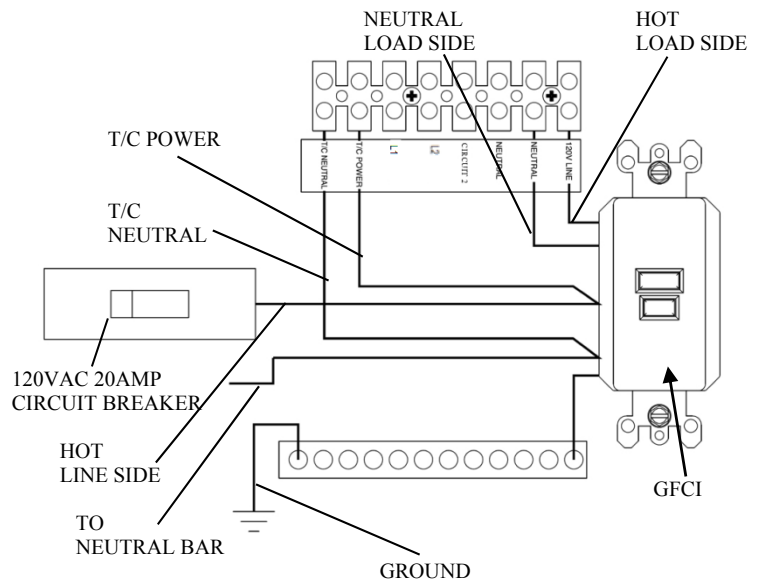

Hooking up Low Voltage Lights to Circuit 1

To connect a Low Voltage lighting product to Circuit 1 (12VAC), an NEC or local jurisdiction approved Pull / Junction / Bell Box must be used to directly connect the conduit from the lighting product, in line with the WPC1-XXXX-T. This box must be a minimum of 4" above ground level and may also serve as a convenient location to store service loop cable. Use appropriate wire from the separate 12VAC output block to supply Low Voltage power from the WPC1-XXXX-T to the approved Pull, Junction, or Bell Box. Use the lower left knockout location(s) and be sure to replace the Isolation Cover using the grounding attachment screw. Lastly - use the supplied cable tie to secure the lighting wiring to the cover.

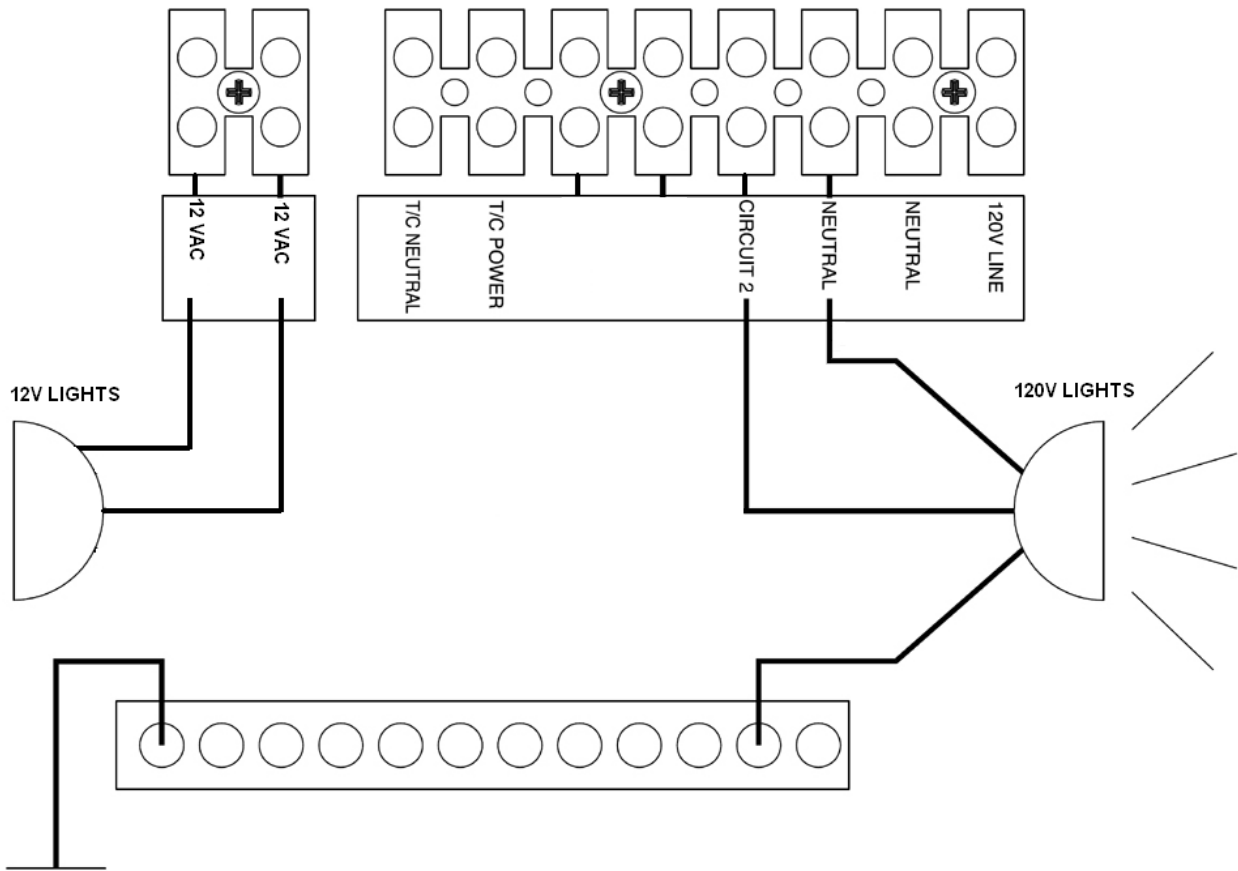

If this product is used to connect 120VAC underwater lights directly, refer to 1999 NEC 680-21(b), 2002 NEC 680-24(b) or CEC 68-060, 062 and 066 for details.

PUMP CONNECTIONS

NOTE: Some models are **ONLY** equipped with Single Speed OR Dual Speed pump connections.

CONNECTING A 240VAC SINGLE SPEED PUMP

Connect a 240V 30AMP Circuit Breaker for each pump (if this control box is equipped with optional pump relays). Using an appropriately sized **copper** wires connect to the outer contacts of the JQX relays of the appropriate pumps as shown. Run wires from the pump to the inner contacts of the appropriate JQX relay.

NOTE: This unit maybe equipped with more then one JQX relay for pump control.

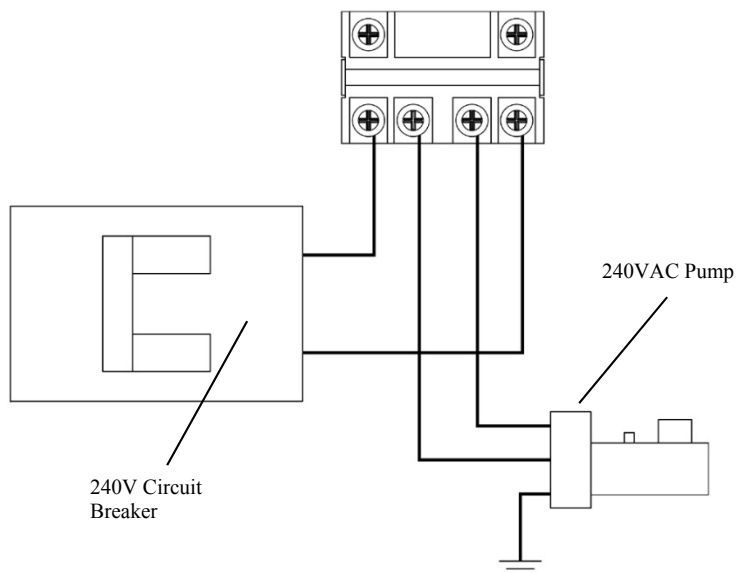

CONNECTING A 240VAC DUAL SPEED PUMP

As illustrated, connect the Low Speed wire to the Low Speed Load terminal on the terminal block. Connect the High Speed wire to the High Speed Load terminal on the terminal block. Connect the 120V Primary from the 240V Circuit Breaker to the 120V PRI INPUT terminal. Directly connect the 120V Secondary from the Circuit Breaker to the 2 Speed Pump.

NOTE: The Secondary 120V must be directly connected to the pump for 240V operation.

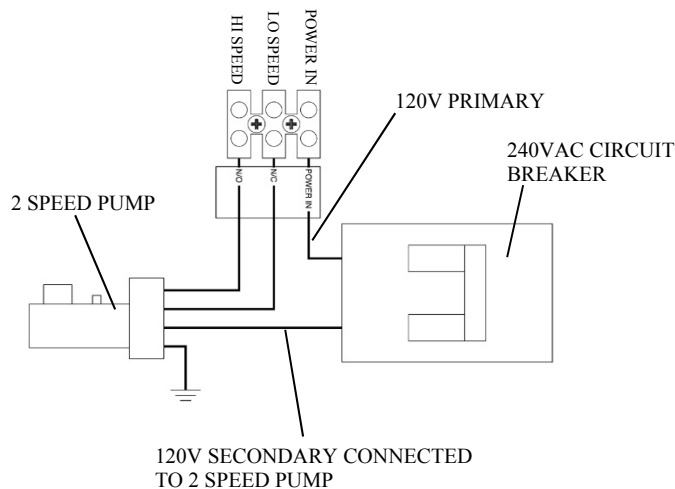

NOTE: Pump Breaker **MUST** be turned **OFF** before servicing as 2nd leg of 240V circuit is **HOT** at all time!

Heater Connection (Optional Equipment).

To connect a heater, run the pilot wires from the heater to the WPC unit. Connect the wires to the terminal block labeled Heater.

NOTE: The Heater circuit only completes the circuit of the Heater terminals when the 24V Valve control is energized to the NO Load circuit.

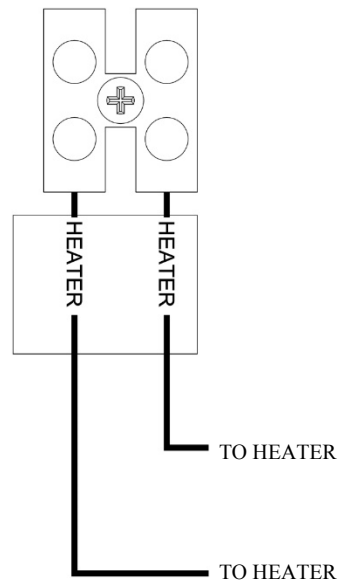

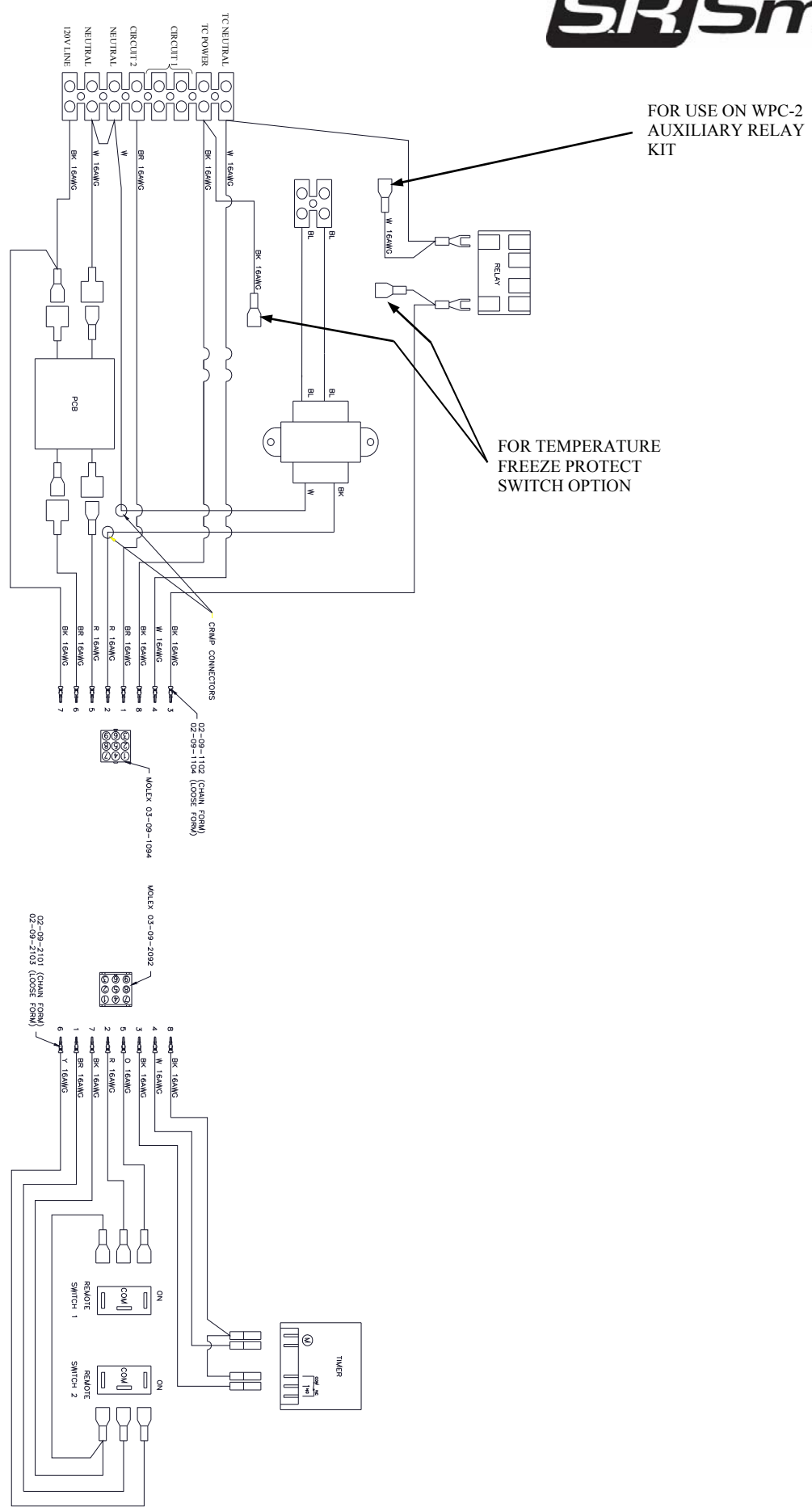

Repeater Mounting

The WPC-1 is equipped with a signal repeater that can be mounted up to 10 feet from the WPC-1 unit. This repeater receives signals from the wireless remote and sends them to the WPC-1 via the 10 foot cable. Establish a location for the Repeater that is in line of sight from where the wireless remote will be used most frequently and that is no more than 75 feet from where the remote will be used. NOTE: If extension is needed, use S.R. Smith part number WE-65 and follow installation instructions supplied with the Repeater Extension.

To mount the Repeater, carefully insert a small flathead screwdriver into groove between the Dome and Base approximately where the locking dimples are located. Pry the Dome out of on of the locking dimples. Then carefully insert the small flathead screwdriver into the groove between the Dome and the Base in an adjacent locking dimple and pry the Dome out. Then separate the Dome from the Base by hand. Using the supplied self-drilling screws, locate a suitable mounting surface and screw the base to this surface. Note that the marking “TOP” must be in the 12 o’clock position and the wire slit must be in the 6 o’clock position. Do not over tighten the screws as it may damage the Repeater base. Realign the Repeater Dome to the Base and ensure that the wire is exiting the base through the slit and the Locking Dimples are aligned with the locking holes. Apply enough pressure so that the Dome “snaps” into the base.

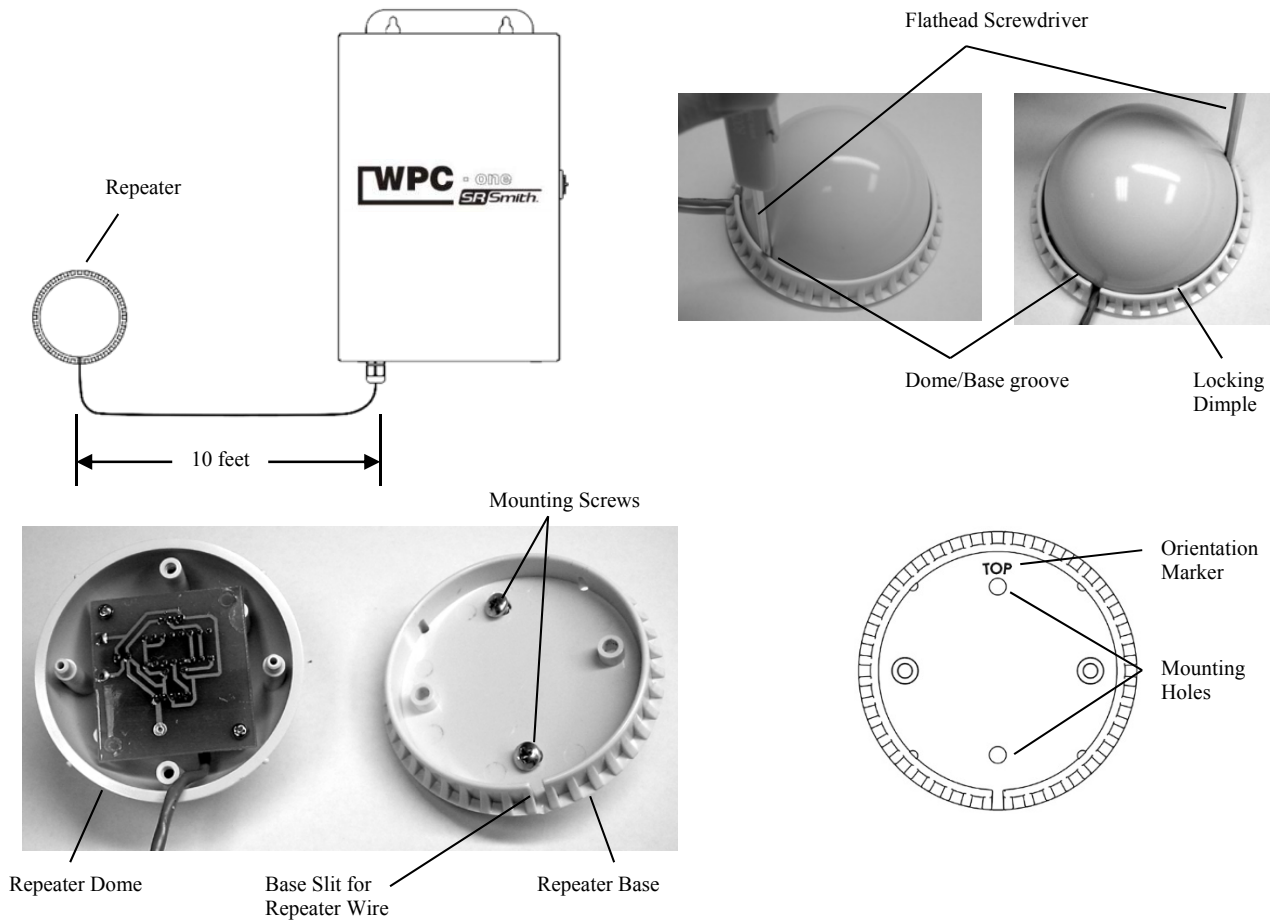

OPERATING INSTRUCTIONS

WPC-1 TOGGLE SWITCH OPERATION

The WPC-1 receiver box houses two toggle switches. For operation with the wireless transmitter, the toggle switches need to be in the REMOTE position. To manually turn ON a device connected to Circuit 1 (12 VAC) or Circuit 2 (120 VAC), flip the switch to the ON position. To manually turn OFF a device, flip the switch to the MIDDLE or OFF position. NOTE: If a toggle switch is in the OFF position, wireless remote operation of the device will be disabled. To re-enable wireless remote operation, flip the toggle switch back to the REMOTE position. NOTE: If a device turns ON when the toggle switch is set to the REMOTE position, turn the wireless remote button OFF to turn off the device.

Units equipped with toggle switches



NOTE: Circuit 1 is in the ON position and Circuit 2 is in the REMOTE position

WIRELESS REMOTE OPERATION

The toggle switches on the WPC-1 must be set to REMOTE for wireless operation. The POWER ON/OFF buttons control each circuit independently. With each push of the button, the WPC-1 toggles from ON to OFF or OFF to ON. For Synchronized operation, both WPC-1 toggle switches must be set on REMOTE before pushing the SYNC ON/OFF button.

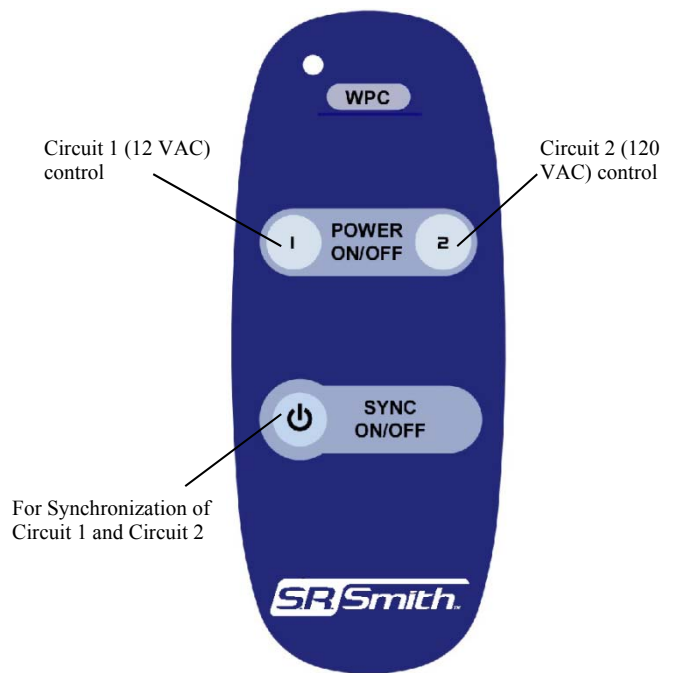

TIMER OPERATION

Set time to current time. In the example below, the current time is set for 9:00pm. **NOTE: Only turn the Timer dial clockwise or the timer will be damaged.** Once the time has been set to the current time, set the hours of the Pump operation by “snapping” the timer tabs inwards towards the center. **NOTE: Each tab represents 15 minutes of operation and tabs set inwards towards the center is for OFF operations and ON when the tabs are set outwards as illustrated.** In the example below, the Pump will be off from 12:00pm to 11:45pm.

Once the time and time of operation has been set, ensure that the Timer function switch is set to Auto for timer control of the Pump as illustrated below. To turn off timers automatic functions, set the Timer function switch to OFF. To manually turn on the Pump, set the Timer function switch to the ON position. **NOTE: When in the ON position, the Pump will continue to run until the Timer function switch is set to Auto where the tabs at the Set Point is in the OFF position or if the Timer function switch is rotated to the OFF position.**

Timer Function Switch Position

- I - ON UP
- ⊖ - AUTO MIDDLE
- 0 - OFF DOWN

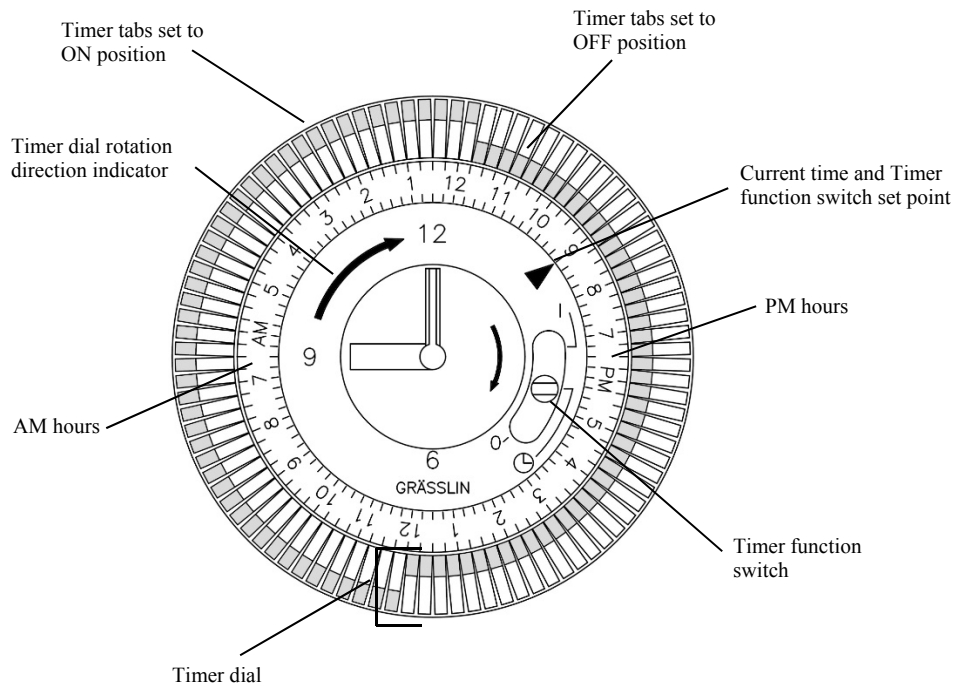

CODE ADJUSTMENTS

If it is necessary to change the transmission code on the WPC-1 an adjustment to the receiver AND the transmitter DIP switches must be performed.

RECEIVER DIP SWITCHES – Turn OFF power to the WPC-1 from the breaker panel. Open the enclosure and unscrew the face plate. Disconnect the Molex connector that connects the front panel controls to the receiver unit and set the face plate on a safe location where it will not be bent, scratched, or impact forces applied to the components or the face plate itself. Unscrew the four (4) screws holding the receiver to the base of the WPC-1 control box. Unscrew the four (4) screws located on the back of the receiver to release the cover. NOTE: Take notice of how the wires enter and exit the receiver. Remove the cover and look on the PCB to locate the DIP switch as illustrated.

TRANSMITTER DIP SWITCHES – Remove all screws from rear of remote. Separate the bottom cover from the top cover.

DIP SWITCH ADJUSTMENT – The four DIP switches have an ON and an OFF position. Changing just one DIP switch will change the code. MAKE SURE BOTH THE RECEIVER AND TRANSMITTER HAVE THE SAME DIP SWITCH SETTINGS.

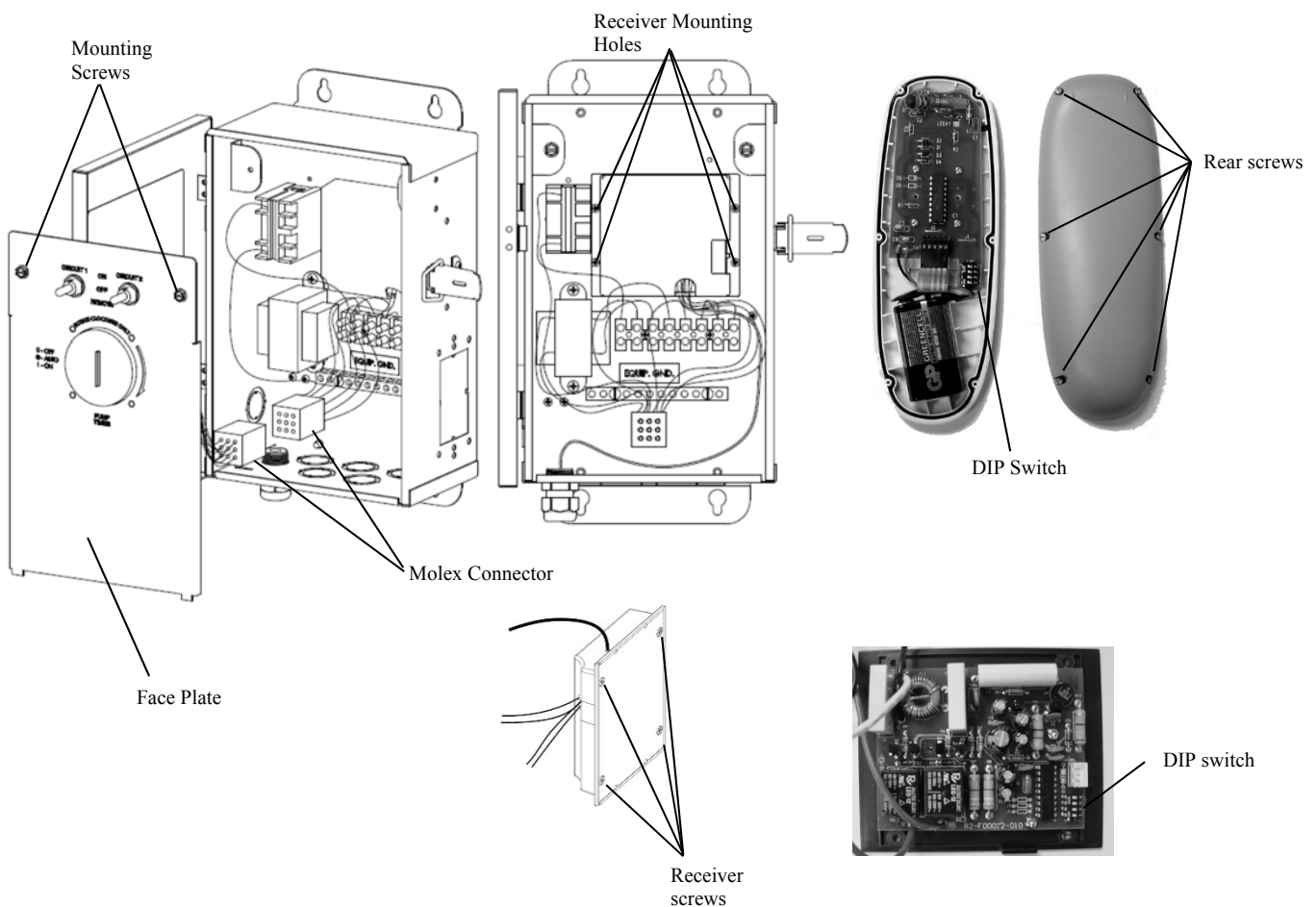

Note: Sample shown is of Channel 9

DIP SWITCH	1	2	3	4
Channel 1	OFF	OFF	OFF	OFF
Channel 2	ON	OFF	OFF	OFF
Channel 3	OFF	ON	OFF	OFF
Channel 4	ON	ON	OFF	OFF
Channel 5	OFF	OFF	ON	OFF
Channel 6	ON	OFF	ON	OFF
Channel 7	OFF	ON	ON	OFF
Channel 8	ON	ON	ON	OFF
Channel 9	OFF	OFF	OFF	ON
Channel 10	ON	OFF	OFF	ON
Channel 11	OFF	ON	OFF	ON
Channel 12	ON	ON	OFF	ON
Channel 13	OFF	OFF	ON	ON
Channel 14	ON	OFF	ON	ON
Channel 15	OFF	ON	ON	ON
Channel 16	ON	ON	ON	ON

CHANNEL

1	5	9	13
2	6	10	14
3	7	11	15
4	8	12	16



DIP Switch