

# Motion Trek 350

153121

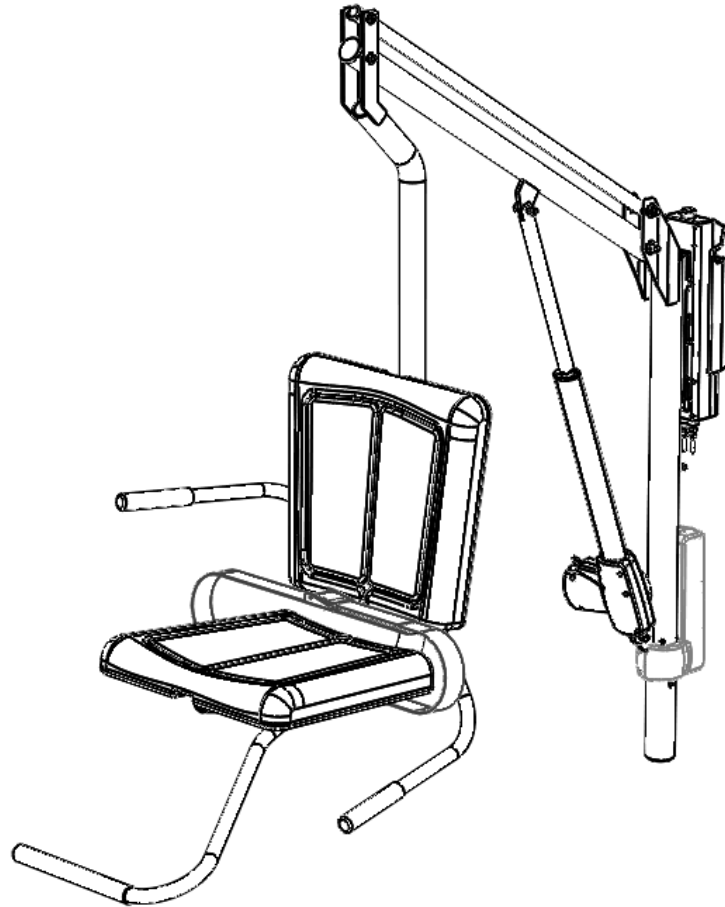

**SPECTRUM**<sup>®</sup>  
*Aquatics*

A PLAYCORE Company

7100 Spectrum Lane ~ Missoula MT 59808  
800.791.8056 ~ [www.spectrumproducts.com](http://www.spectrumproducts.com)

You have purchased a Spectrum Products Motion Trek 350 assisted access lift. Providing the unit is installed correctly and properly maintained, it will furnish you with many years of trouble-free use. It is important to read this entire manual prior to beginning assembly or operation.

### Shipping Information:

Each lift will arrive partially assembled in one box. Before accepting the lift from the carrier, inspect for visible damage and match the contents with those listed below. Spectrum is not responsible for lost or damaged freight.

The box will contain all structural components and hardware. The following is a list of the components included with your shipment from Spectrum. Use Components and Hardware Figure, Page 2, as a reference to identify each item listed.

1	Mast & Boom assembly	2	Seat Halves
1	Actuator	1	Footrest assembly
1	Seat Belt	1	Battery
1	Seat pole assembly	1	Handset
1	Charger	2	Flip Down Armrest Assemblies
1	General hardware	1	Anchor

### IMPORTANT SAFETY INSTRUCTIONS

**When installing and using this electrical appliance, basic precautions should always be followed, including the following:**

#### READ ALL INSTRUCTIONS BEFORE USING

**WARNING** – To reduce the risk of injury, do not permit children to use this product unless they are supervised at all times.

A wire connector is provided on this unit to connect a minimum 8 AWG (8.4 mm<sup>2</sup>) solid copper conductor between this unit and the means of local equipotential bonding.

Check the unit periodically for signs of deterioration

Keep all nuts, bolts, and screws tight to be sure the lift is in safe working condition.

## Components and Hardware:

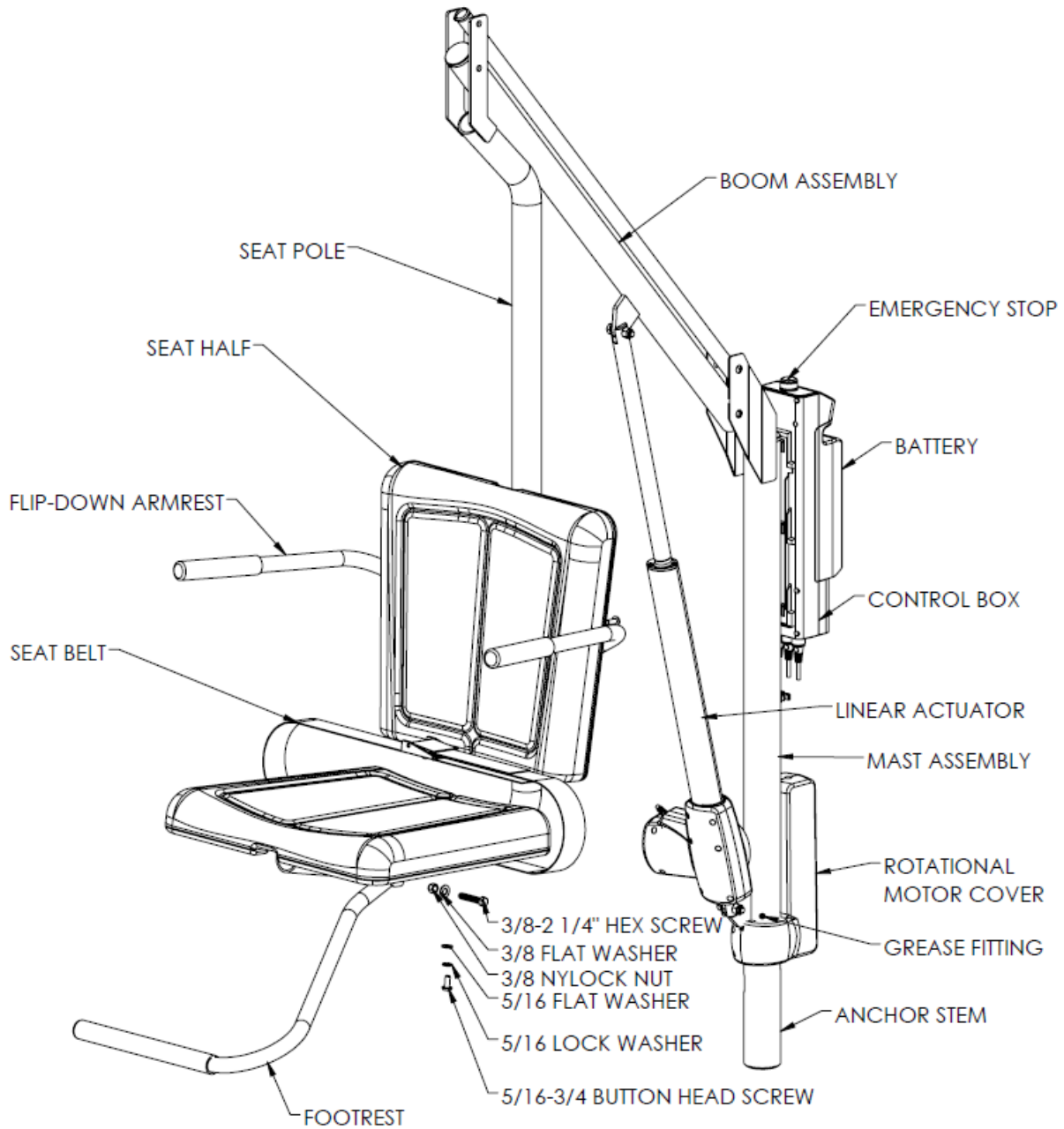

SOME HARDWARE OMITTED FOR CLARITY  
HANDSET, ANCHOR, AND CHARGING ACCESSORIES NOT SHOW

## Installation Overview

Read all instructions before attempting to assemble or install the lift.

### Clear Deck Space:

The lift must be installed in a location that is clear from obstacles and other hazards in order to be compliant with ADA guidelines. Clear deck space is defined by the figure to the right. This rectangle is 48" long (along the pool wall) and 36" wide.

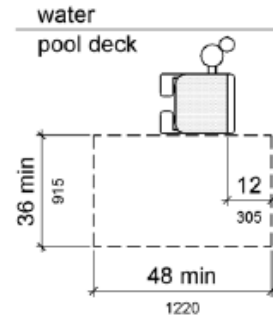

### Pool/Spa Depth:

To comply with ADA guidelines the lift must be installed where the water depth does not exceed 48". If the entire pool is deeper than 48" this requirement does not apply.

### Anchor Location/Installation:

The lift anchor centerline must be no less than 6", but no greater than 22" from the pool/spa wall (or any feature that sticks out past the pool/spa wall, such as a coping). The lift is installed in a single 2.375" I.D. anchor.

### New Construction Anchor Installation

- Place the anchor in the desired location previous guidelines.
- Locate a bonding source to bond (ground) the anchor. The steel rebar-bonding grid of the pool deck is the best choice for bonding the anchor. Attach a No. 8 solid copper wire (NEC Section 680-22) from the bonding bolt on the base of the anchor to the bonding grid.
- Secure anchor in place at the proper height – anchor may be cemented in place. Set the anchor so that the finished top is 1/8" to 1/4" below finished deck level – allowing for anchor cap to be put in place when the lift is not in use.
- Use the carpenter's level to level the anchor making sure the lift mast will be vertically straight up and down (perpendicular to the deck) in all directions. It is important that the mast be vertically straight to ensure ease of rotation when the lift is fully loaded.
- Place tape over the anchor hole before pouring concrete deck – not allowing concrete to enter anchor opening.
- Pour concrete deck and finish.

Allow the concrete to cure for at least seven days before installing and using the lift.

### Existing Facility Anchor Installation

There are many different configurations of footing shapes and sizes to resolve the forces of the lift; a general case footing that has been calculated for Spectrum is a minimum slab 2'6" Square

by 10" thick anchor centered, with a minimum of four #4 bars each way centered. An engineer stamped letter can be furnished by Spectrum if requested.

- a. From the center of the desired anchor location, using a marking pen or chalk, mark a square of the dimensions provided by Spectrum Aquatics, or another engineer stamped footing. This is the concrete to be removed to accommodate the installation of the lift's anchor. It is recommended that the anchor be located at least 6" from any expansion joint, crack, drain, or similar structure in the concrete deck.
- b. Use a concrete cutting saw; cut the square out of the existing concrete deck. Using a heavy/sledge hammer to break the cut section of concrete – remove the section of concrete from the deck. See Figure 1.

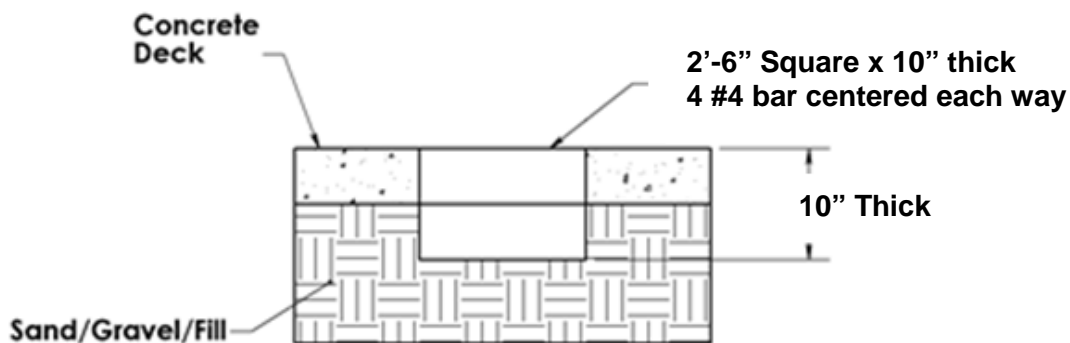

Figure 1

- c. Locate a bonding source to bond the anchor. The steel rebar-bonding grid of the pool deck is the best choice for bonding the anchor. Attach a No. 8 solid copper wire (NEC Section 680-22) from the bonding bolt on the base of the anchor to the bonding grid.

**Note:** If the concrete deck is 8" thick or more, an alternative anchor installation method may be used. In lieu of cutting the concrete deck with a saw, a concrete core drill may be employed to cut a 4" diameter hole at the desired anchor installation location. Epoxy or hydraulic cement may be used to secure the anchor in place. Make sure the anchor is properly bonded.

- d. Place tape over the anchor hole before pouring concrete – not allowing concrete to enter anchor opening.
- e. Fill the hole in the deck around the anchor with non-expanding concrete. Set the anchor so that the finished top is 1/8" to 1/4" below finished deck level – allowing for anchor cap to be put in place when the lift is not in use.
- f. Use a carpenter's level, to level the anchor making sure that the lift mast will be vertically straight - up and down (perpendicular to the deck) in all directions. It is important that the mast be vertically straight to ensure ease of rotation when the lift is fully loaded.

Allow the concrete to cure for at least seven days before installing and using the lift.

## Assembly Instruction

The following tools will be required to complete assembly and installation of the lift:

- 9/16" ratchet and open-end wrench
- 5/8" ratchet and open end wrench
- 1/2" ratchet or open-end wrench
- 3/16" hex key (allen wrench)

### Lift Assembly

- a. Fully charge lift battery.
- b. Stand the mast assembly up in the anchor that is installed in the pool/spa deck
- c. Attach the actuator end fitting to the lifting arms using:

- 1 – 7/16" x 1 3/4" Hex cap bolt
- 1 - 7/16" Nylock nut

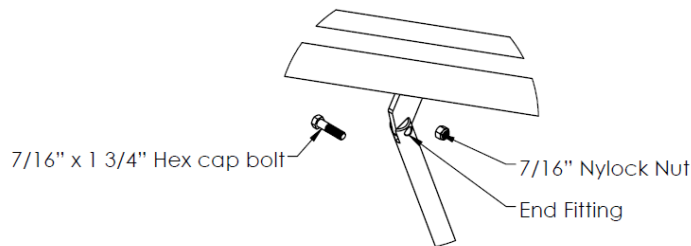

- d. Tilt the battery into the receiver until it locks into place.
- e. Plug the handset into the remaining port on the control box, making sure the connector is properly aligned.

**NOTE:** It is very important that the plug is fully inserted into the control box. If the handset plug is not fully inserted into the control box, the lift will not operate.

- f. Test lift operation by pushing the up and down toggle switch on the handset to ensure the lift is operational (See Page 8 for instructions on using handset). Then run the actuator into the fully extended position by pressing the up button until the actuator stops moving. Leave the lift in this position for the following steps.

- g. Join the seat arm to the mast assembly using:

- 2 - 3/8" Shoulder 2 1/2" x 5/16" thread
- 4 - 3/8" Flat washers
- 2 - 5/16" - 16 Nylock nut
- 2 - Donut shims

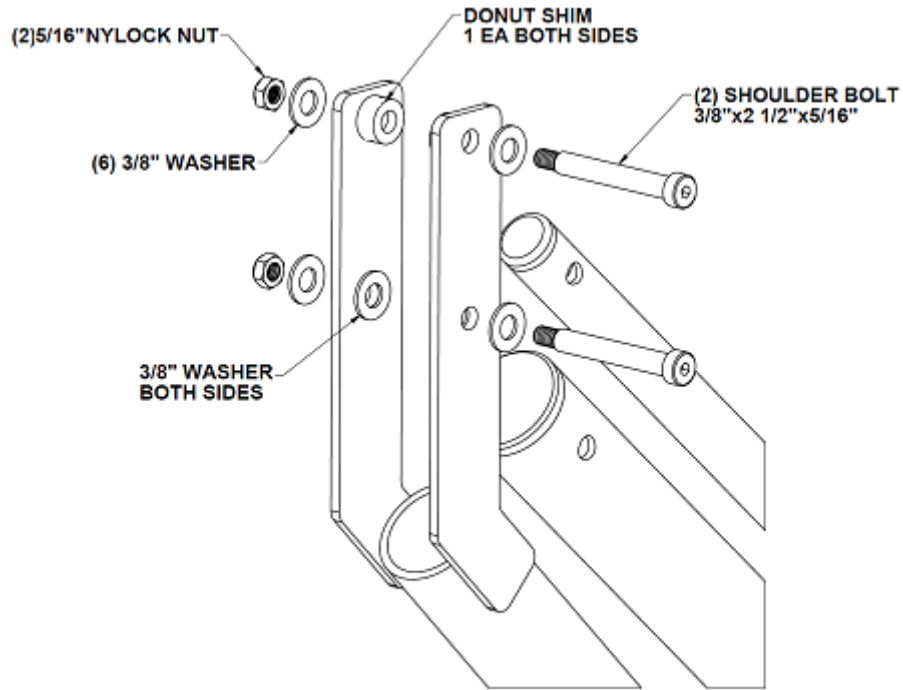

Attach the seat half and the seat belt to the mounting plate of the seat arm using:

- 2 - 5/16"-18 x 1"
- 2 - 5/16"-18 x 3/4"
- 4 - 5/16" Flat washers
- 4 - 5/16" Lock washers

*Note: When attaching the seat belt use 5/16"-18 x 1" as shown below:*

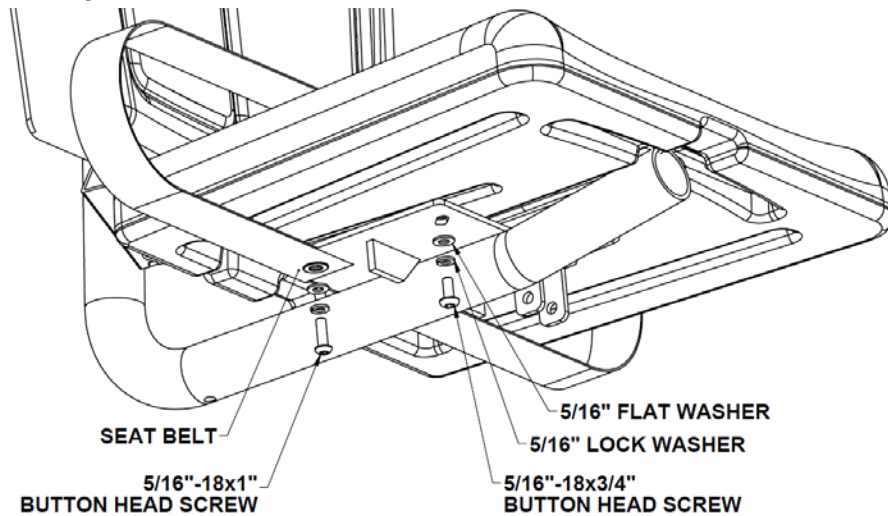

- h. The image below shows the proper way to assemble the seat belt.

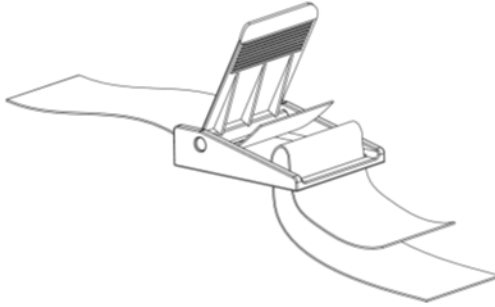

- i. Attach the other seat half to the back rest mounting plate using:

4 - 5/16"-18 x 3/4"  
4 - 5/16" Flat washers  
4 - 5/16" Lock washers

- j. Attach the footrest to the seat arm assembly using:

1 - 3/8" – Hex bolt 2"  
1 - 3/8" Flat washers  
1 - 3/8" Nylock nut

*Tighten the bolt until the flat washers are snug, and then back off until the footrest pivots freely. Adjust footrest to desired height using installed 3/8" - button head bolt.*

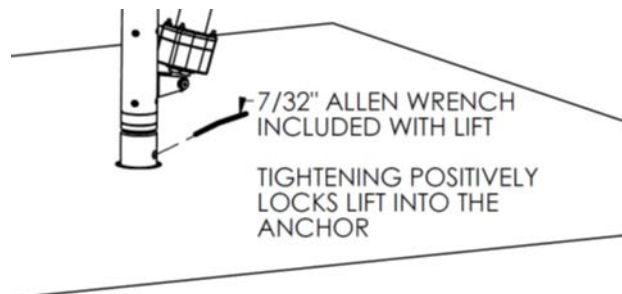

- k. Tighten the anchor locking bolt by access through a hole one inch up from the top of the anchor on deck. The included 7/32 Allen wrench will fit a 3/8" button head internal to the mast. This internal fastener is at an angle and can be tightened down until there is no lift movement in the anchor. The figure above shows the location and approximate angle of the anchor locking mechanism for the lift.

- l. Test the lift for proper operation.



# Operator's Guide

## Lift Operation

**WARNING!** Read all operating instructions before operating the lift. Make sure that all individuals using the lift have read the instructions and have been made aware of all safety precautions.

**WARNING!** Operate the lift exactly as described in the instructions above. Failure to do so may result in damage to the lift or personal injury.

**WARNING!** Do not exceed the maximum lifting capacity of 350 lbs. This may result in damage to the lift or personal injury.

**WARNING!** Do not rotate the lift directly into the deck or pool/spa wall. This may result in damage to the lift or personal injury.

**WARNING!** Unless operating in an emergency, Lift should not be forced to rotate. This will cause damage to the rotational components of the lift.

**WARNING!** Use extreme caution when transferring to or from the lift; it is the responsibility of the user to allow for safe operation of this lift.

## Basic Lift Operation.



### **Lifting (UP)** :

Pressing the  button causes the seat to rise. The seat will continue to rise as long as the button is pressed or until the lift reaches its highest extent. Releasing the button at any time during travel will also cause the lift to stop.

### **Lowering (DOWN)** :

Pressing the  button causes the seat to lower. The seat will continue to lower as long as the button is pressed or until the lift reaches its lowest extent. Releasing the button at any time during travel will also cause the lift to stop.

### **Rotation (CLOCKWISE) 🌀:**

Pressing the 🌀 button causes the lift to rotate clockwise. The lift will continue to rotate in this direction as long as the button is pressed. Releasing the button at any time during rotation will stop the lift from rotating.

### **Rotation (COUNTERCLOCKWISE) 🌀:**

Pressing the 🌀 button causes the lift to rotate counterclockwise. The lift will continue to rotate in this direction as long as the button is pressed. Releasing the button at any time during rotation will stop the lift from rotating.

## **Battery Control Panel Instructions and Operation**



### **Emergency Knob & Button:**

The emergency button will operate at any level of battery life. Pressing the button will stop all lift motion. To resume normal lift operation procedures, the knob must be turned in the clockwise direction.

### **Battery Light:**

If any of the four arrow buttons are pressed, the battery light will illuminate. The battery light has a total of three bars. If all of the bars are illuminated the battery is at or near full capacity. Two illuminated bars indicates the battery should be charged soon. A single bar illuminated means the battery should be charged before the next chair lift cycle.

**Note:** The control system will beep audibly every 5 seconds once the battery reaches ~20% capacity remaining. If this beep is present the battery should be charged before using the lift.

### **Lifting:**

Pressing the up (^) arrow causes the seat on the lift to rise. The seat continues to rise while the button is pressed or until the lift reaches its highest extent. If the button is released, the lift will stop moving upward.

### **Lowering:**

Pressing the down (v) arrow causes the seat to lower. The seat will continue to lower while the button is pressed or until the lift reaches its lowest extent. If the button is released, the lift will stop moving downward.

### **Clockwise Rotation:**

Pressing the right (>) arrow causes the seat to rotate clockwise. The seat will continue to rotate while the button is pressed. If the button is released, the lift will stop rotating clockwise.

### **Counterclockwise Rotation:**

Pressing the left (<) arrow causes the seat to rotate counterclockwise. The seat will continue to rotate while the button is pressed. If the button is released, the lift will stop rotating counterclockwise.

To enter the Pool or Spa:

- A. Position the chair of the lift over the deck in a suitable position for a transfer using the directional buttons on the transmitter
- B. Carefully transfer into the lift seat from mobility device
- C. Fasten seatbelt
- D. Rotate the lift over the water, where it will not come into contact with the pool edge or any obstruction using the left or right buttons on the transmitter
- E. Lower the lift into the water until buoyant, by pushing the down button
- F. Unfasten seatbelt and carefully move away from the lift
- G. Using the directional buttons on remote return lift chair to an on deck position not over the pool

To Exit the Pool or Spa:

- A. Recall lift chair into water to the previous depth and position upon transferring from the lift seat to the pool using directional arrows
- B. Carefully transfer into the lift seat from water
- C. Fasten seatbelt
- D. Lift the seat straight up using the “up” directional arrow on the transmitter until top of lifting stroke is reached
- E. Rotate the chair into a suitable position on deck to transfer from lift seat
- F. Unfasten Seatbelt
- G. Carefully Transfer from lift seat into mobility device

### **Battery Charging & Installation**

The battery comes partially charged, but will need charging after the first several hours of use. Charging time is approximately 12 hours for the first few charges, four hours after the first two full battery cycles. The lift comes with a battery charger for use in dry locations. Charge the battery as follows:

Plug the battery charger into a standard electrical outlet\*. The green LED on the charger will illuminate, indicating that the charger is on.

Plug the charging cable into the charging port on the battery cradle. Place battery in charging cradle. If the battery is up to the charged voltage, the LED on the charger will stay green. If the charger determines that the battery needs to be charged, the LED on the charger will change to red.

The red LED will turn green when the battery is fully charged. This charger has internal monitoring circuitry that will not overcharge the battery, if the battery is left on the charger for extended periods of time the charger will go into short charging cycles at intervals to keep the charge level at optimal.

#### **\*Charger accepts 110 VAC**

When the battery is fully charged, remove it from the charging cradle and install the battery on the lift. The Battery Capacity Indicator on the receiver will show a green LED, indicating that the battery is fully charged and installed properly. When the LED changes to amber the lift is still OK to use. However, when the LED changes to red, or an audible tone is heard during a lift cycle, the battery pack needs to be recharged.

**To keep the battery from discharging to the point of causing damage, it is important to charge the battery at least once monthly, even if the battery has not been installed on the lift.**

After initial break-in, the battery should last approximately 90 cycles at the full 350-lb load rating of the lift before it needs recharging. The battery will need to be replaced after 500 to 800 charge cycles or three to four years if properly maintained (approximately 20,000 lifting cycles).

#### **Care and Maintenance**

The following should be performed periodically to ensure safe and dependable use.

1. Remove any discoloration with a 3M scratch pad (stainless steel components only). Wipe clean with a sponge dampened with Spectra Clean. Repeat these steps several times to passivate the stainless steel. Lift maintenance kits are available from Spectrum (Part Number 152161-MT). Do not spray with high-pressure water, only clean with non-chlorinated water.
2. Check all electrical connections – Check any external electrical cables for wear and/or breakage in the outer insulation.
3. Check all mechanical connections – inspect the Nylock nuts on all moving parts and make sure they are snug. Lubricate all pivot points with light oil (3-1).
4. To maintain the battery properly, the battery must be fully charged monthly. If the battery goes for longer than three months without a charge, the battery will have significantly reduced capacity.

5. Apply dielectric grease to the battery connections and receiver connections where the battery and receiver meet.
6. Grease bearing assembly every 6 months using the grease fitting at the bottom of the mast.

## Troubleshooting

<b>Problem:</b>	<b>Cause:</b>	<b>Solution:</b>
1. Lift will not operate at all:	Low battery (Lift) – Control box beeps audibly every 5 sec  Handset not completely plugged in	Recharge battery  Fully plug in handset
2. The seat will not raise or lower:  The seat will not rotate:	Low battery  Battery not installed properly  Receiver malfunction	Recharge battery  Reinstall battery  Replace receiver*
3. The seat's motion isn't smooth or sticks at a certain point during travel:	Excessive wear to bearings  Excessive wear to actuator	Replace bearings*  Replace actuator*
4. The seat travels much slower than normal:	Low battery	Recharge battery
5. The lift makes much more noise or unusual noises during operation:	Excessive wear to bearings  Pivot points galling	Replace bearings*  Oil pivots with light oil (3-1)
6. Battery will not charge:	Bad battery (red LED on charger – not turning orange or green in 4 hours or less)	Replace battery*

\*Please contact your local distributor or Spectrum Customer Service to order parts 406.532.6321