

Mendota 48" & 60" Portable Lifeguard Chair

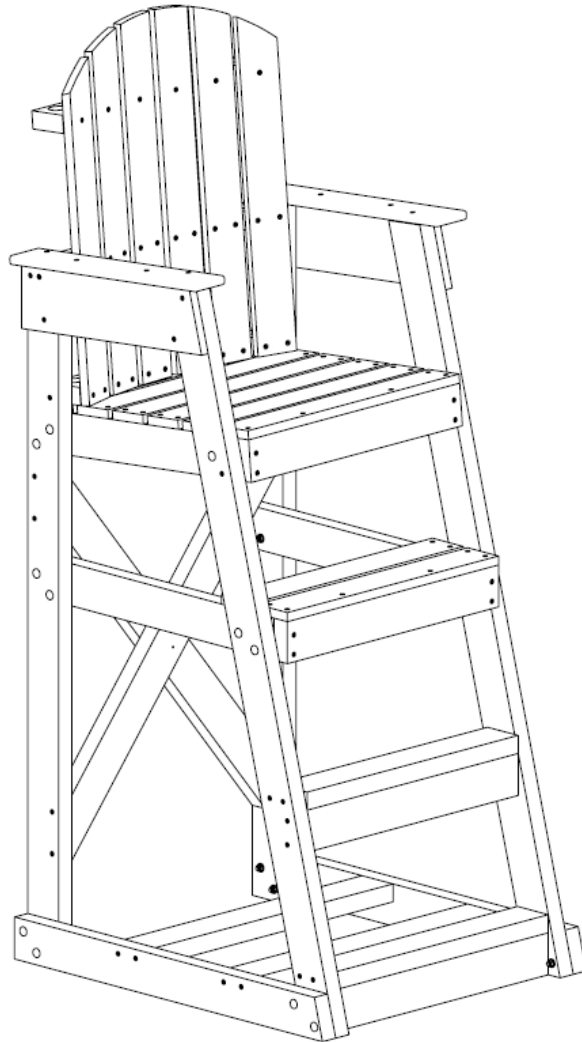

Owner's Manual Assembly and Installation



7100 Spectrum Lane
Missoula, Montana 59808
406.542.9781 ~ Fax: 406.542.1158

Mendota 48" Assembly:

Tools Required:

- Drill with Quad Head Bit
- 1/2" Open End Wrench
- 1/2" Socket and Ratchet
- Mallet

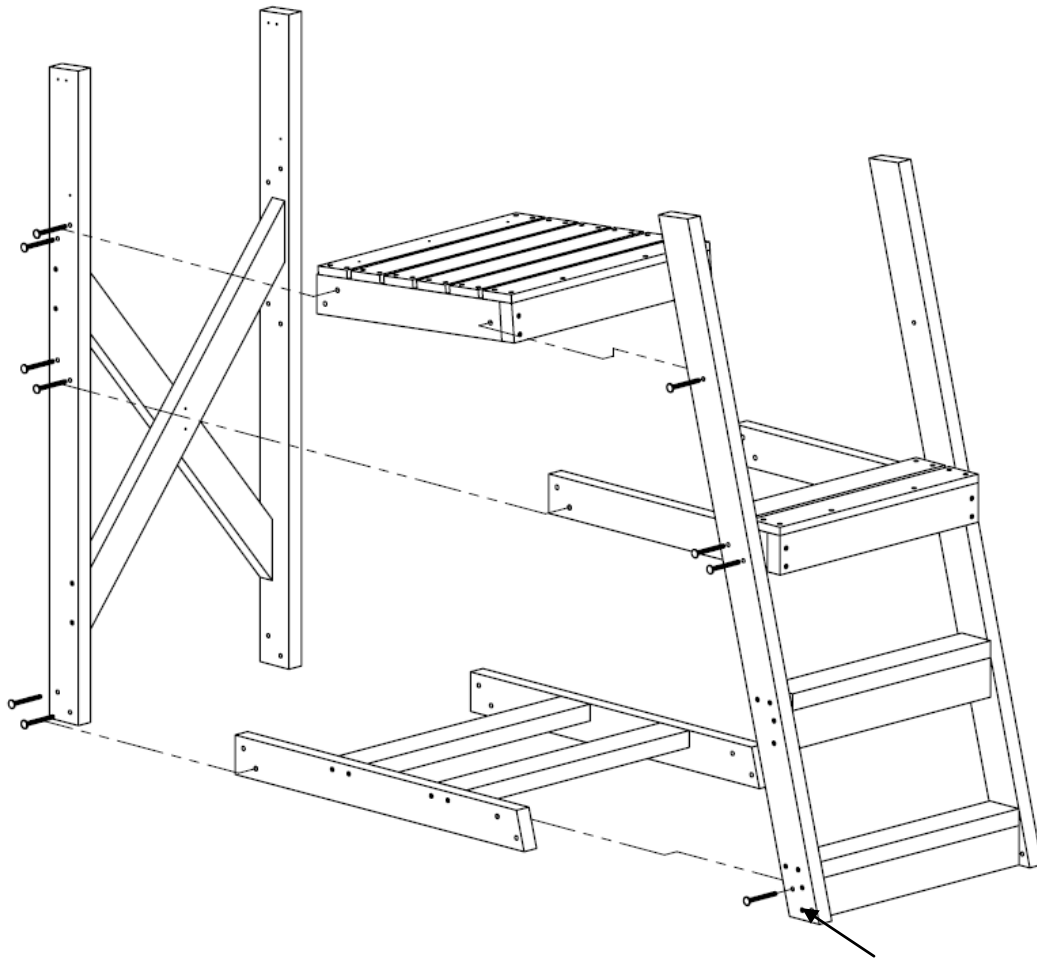

DETAIL A

No bolt necessary on
this model as shown
here

- 1) Assemble main frame together as shown on one side in Detail A, *making sure to leave hardware loose*, using:

5/16" x 3 1/2" Carriage bolts
5/16" Lock Washers
5/16" Hex Nuts

*Note: Set up the chair on a flat surface, this will make installation of hardware much simpler.

*Note: Set the heads of the carriage bolts into the HDPE lumber with the mallet before tightening; do not over tighten the hex nuts.

- 2) As shown in Detail B, screw together the armrest stiffener (both sides) making sure to **screw into the existing holes**, using:

8 - 1 1/2" Quad Head Screws

*Note: It is important not to over tighten the stainless steel screws, this leaves a depression in the surface where water and contaminants can build up.

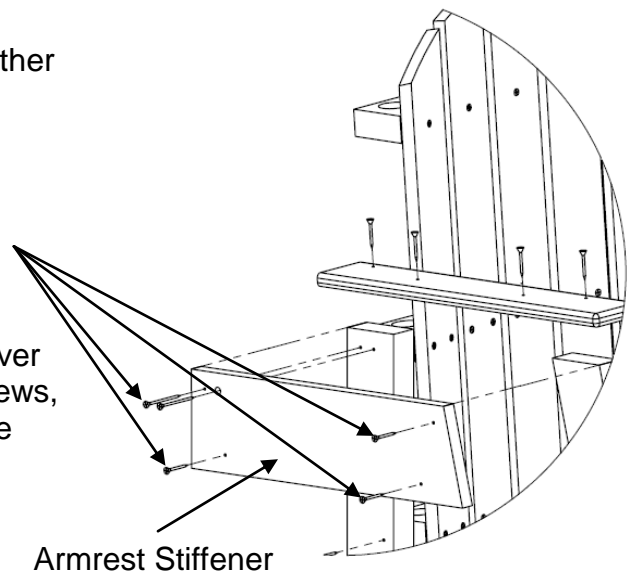

DETAIL B

- 3) Tighten all hardware from step 1
- 4) As shown in Detail C, attach seat back to seat bottom (please use existing holes) using:

2 - 1 1/2" Quad Head Screws

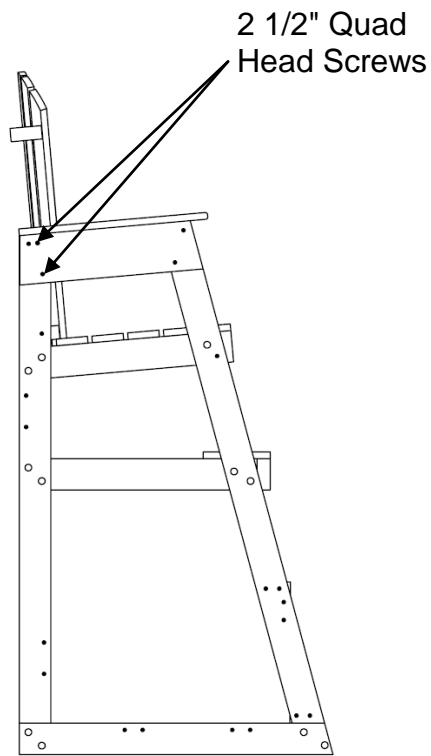

DETAIL D

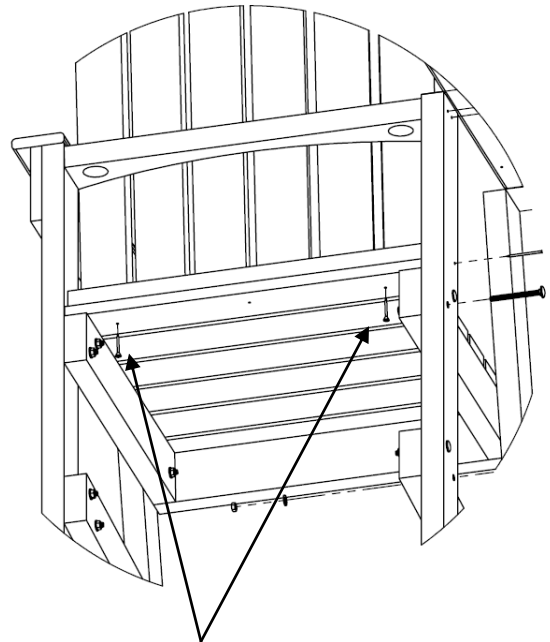

DETAIL C

- 5) Attach the seat back as shown in Detail D making sure to screw into existing holes, using:

4 – 2 1/2" Quad Head Screws

- 6) Then attach armrest as shown in Detail E using:

4 – 1 1/2" Quad Head Screws

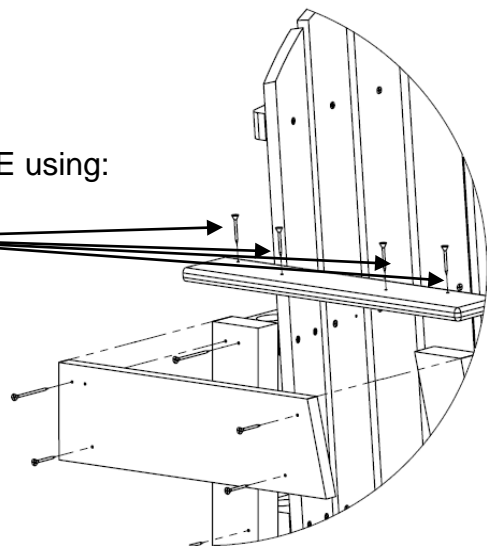

DETAIL E

7) For 60" Mendota Slide Base Support in as shown;

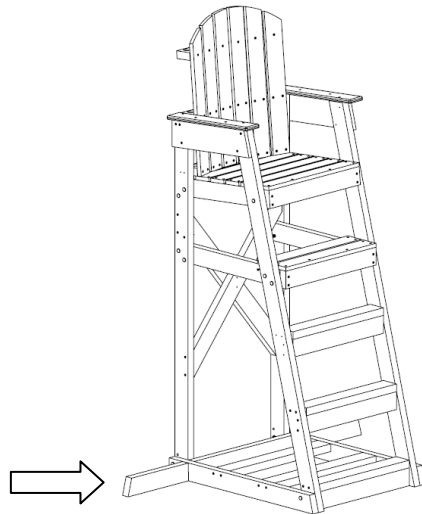

8) Attach wheels as shown using;

- 2 - BOLT CB 5/16"-18x3 1/2" TYPE 316
- 4 - FLAT WASHER 5/16"
- 2 - 5/16" NYLOCK NUT

